

WHAT WILL IT TAKE ? CHANGING THE STORY FOR PALESTINIANS

NIESR

20 MAY 2024

نهضة PALESTINE
فلسطين EMERGING



National
Institute of
Economic and
Social Research

ECONOMIC RECONSTRUCTION AND GROWTH

20 MAY 2024

PREP

the work done so far

THE PLAN

what is it ?

GAMECHANGERS

where we are now

NEXT STEPS

what do we want from you

PREP |

Work Done So Far

- PREP is the Palestinian Reconstruction Economic Partnership, a strong and diverse group of the Palestinian private sector, global experts and relevant international organisations
- This loose, consensus-based, pro-bono coalition of leaders has held together as a robust plan for Palestinian economic reconstruction and development has been elaborated
- After several months work, workshops, working groups, substantive discussions and editing, “Palestine Emerging” has been finalised as a strong foundation on which to build
- **Timing: Why Now ?**
Very hard to consider reconstruction at this time. However:
from start, takes 6-12 months to ramp up: save that time
West Germany had a plan a decade before the Wall fell
pro bono resource clear of monetary considerations
- **Preconditions: Health Warning**
No-one under any illusions that any serious economic reconstruction and sustainable development possible without a fundamental, permanent change in political/security situation

LONDON | First Workshop

- An initial group assembled with the war on Gaza in full force, seeking to create progress from disaster, defining the moment as the end of an era and a new paradigm for Palestinian economic reconstruction and development
- Came to consensus view across people and organisations of need to look beyond the immediacy towards substantial propositions on which real, sustainable growth for Palestine can be anchored
- Agreed to start the work by publishing a credible, new paradigm economic plan that can win the confidence of major global economic institutions, such as the World Bank, DFC, Gulf SWFs and EBRD, as well as the two parties
- To build on work done before, which should be brought together in a catalogue and available on a website as an accessible repository

WASHINGTON | Second Workshop

- Broader, US-based group came together; war was still raging
- Major engagement with US stakeholders, and the original Palestinian, European and other partners; others plans eg UNDP reviewed
- Full day of discussions and developments at USIP, challenging view of “simple” return to status quo, with more powerful need for fundamental change to substantiate building back better
- Support and challenge for major “Gamechanger” interventions that partnership broadly supports and wants to deliver, despite the obvious obstacles, as they represent real step change for the Palestinian economy

WEBSITE | palestine-emerging.org

- Chapters and summaries of the foundational “Palestine Emerging” blueprint
- Catalogue of work, with links to wide variety of relevant source materials and studies, including by Rand Corporation, World Bank, Palestinian private sector, Portland Trust, PA and others
- Open call, and team still adding to this repository of knowledge, including with summaries of relevant activities being undertaken by other organisations so becomes a centre of intelligence
- Insights from survey work in Palestine and underpinning analysis and economic modelling



Download Blueprint		
1 PROLOGUE Description of initiative	2 FOUNDATIONS Context and assumptions	3 URBANIZATION Coordinated development
4 CONNECTIVITY Urban development, mobility	5 NETWORKS Energy, water, digital	6 SOCIAL ASSETS Health, housing, education
7 GROWTH Industrial sectors, new economic paradigms	8 SOFT POWER Culture, creativity, entertainment	9 ENGAGEMENT Governance, participation

PUBLICATION | April 2024 Coverage



U.S. INTERNATIONAL CANADA ESPAÑOL 中文

SUBSCRIBE FOR £0.50/WEEK

LOG IN

Sunday, April 28, 2024
Today's Paper

The New York Times

Dow +0.4% ↑

U.S. World Business Arts Lifestyle Opinion Audio Games Cooking Wirecutter The Athletic

Even With Gaza Under Siege, Some Are Imagining Its Reconstruction

International development agencies have been meeting with Middle East business interests and urban planners to map out a future for the territory.
7 MIN READ



News Politics Opinion Culture Money Sport Life & More Puzzles Newsletters

UK World Scotland Health Education Technology Science Environment Business Housing

The United States and France have sent their top diplomats to the Middle East for new talks about the war in Gaza.

See it **NZZ**
A port island, a university for reconstruction, a connection to the West Bank - how Gaza could become the Singapore of the Middle East

There is still war in the Gaza Strip. But what happens the day after? An international group of experts has drawn up a vision for the Palestinian territory. You would like to advance this economically with many key projects.

Shirka Dasha, Tel Aviv
April 20, 2024, 9:43 a.m. 8 min



A residential building badly damaged by the war in Rafah in the southern Gaza Strip.

Once Israel's war against Hamas in the Gaza Strip is over, the focus will be on reconstruction. Once again, it has to be said, the debris field has never been so gigantic. It would probably take eight to ten years just to dispose of all the rubble. This was calculated by an international group of experts. But above all, she also drew up a visionary plan for Gaza for

The international plan to rebuild Gaza: port, networks, universities and the state for the Palestinians

The Palestine Emerging Initiative aims for development in the coming decades. Baron Frankal, one of the promoters: «The resolution of the political and security issues are preconditions». The role of the USA and Saudi Arabia

by Ugo Tramballi
April 21, 2024



The destruction in Rafah

Listen to the audio version of the article

5' read

An offshore port on an artificial island, the airport, 540 thousand residential units; 160 thousand new jobs and a per capita GDP of 9 thousand dollars, that of a middle-income country. Commerce, industry, urban planning, terrestrial connectivity, high-speed rail and 5G; desalination and renewable energy, the heart of an economic mega-region halfway between Eurasia and Africa.

It may seem strange to describe it like this but we are talking about the Gaza Strip: what it will be like in 2050 at the end of its reconstruction, after a gradual path that includes more urgent things to do by 2030: eliminate the destruction left by the

Gaza postwar plan includes port, 5G network, mass job creation and 1,000% GDP growth

Multinational project backed by Palestinian civil society leaders sets out a vision for devastated enclave



The Palestinian Reconstruction Economic Partnership aims to build a new Gaza from the ruins (Photo: Getty)

By Kieron Monks

April 30, 2024 6:00 am (Updated 8:02 am)

Share icons: X, WhatsApp, Facebook, Email, Print

A group of British, American and Middle Eastern businesspeople and philanthropists have set out an ambitious vision for Gaza to be transformed through a programme that includes job creation, a digital revolution, modern transport networks, connections to the outside world and building an elite football team.

The Palestinian Reconstruction Economic Partnership (Prep), which began with a meeting in London last December, brings together economic development specialists, financial institutions, Palestinian civil society leaders, architects and planners to deliver a postwar plan for the besieged enclave that has been devastated six months of war.

Even With Gaza Under Siege, Some Are Imagining Its Reconstruction

International development agencies have been meeting with Middle East business interests and urban planners to map out an economic future for the territory.



By Peter S. Goodman

On a December morning in central London, more than two dozen people drawn from influential institutions across the Middle East, Europe and the United States gathered in a conference room to pursue an aspiration that, at that moment, verged on preposterous. They were there to plan for the reconstruction and long-term economic development of Gaza.

Gaza was under relentless bombardment by Israeli military forces in response to terrorist attacks launched by Hamas in October. Communities throughout the territory were being reduced to rubble, and tens of thousands of people had been killed. Families confronted the immediacy of hunger, fear and grief.

Yet at the meeting in London, members of the international establishment discussed how to eventually transform Gaza from a place defined by isolation and poverty into a Mediterranean commercial hub centered on trade, tourism and innovation, yielding a middle class.

The group included senior officials from American and European economic development agencies, executives from Middle Eastern finance and construction companies and two

ECONOMIC RECONSTRUCTION AND GROWTH

20 MAY 2024

PREP

the work done so far

THE PLAN

what is it ?

GAMECHANGERS

where we are now

NEXT STEPS

what do we want from you

CONTEXT | Palestinian Economy, Broken By The War

Starting point

low base, regulatory, mobility restrictions, poor infrastructure

West Bank - downturn and damage in all sectors

trade, tourism, industry, transportation, credit, supply chain

Gaza – unprecedented damage (March)

1.7m displaced/extensive loss of life

54-62% all structures damaged/destroyed

80% GDP decline Q4 23

unemployment up 80%

housing reconstruction costs \$15b

Inflation

15%, 3.27% January, unemployment 46%, 8% contraction, 2023

PMA stress tests for resilience Palestinian banking system

exposure to public sector, workers

withholding of clearance

PRECEDENTS | Learning From Others

post-conflict / post-disaster recovery

translation to value in Palestinian economic reconstruction needs

Mosul

Bosnia

Ukraine

Puerto Rico

Turkey

New Orleans

long period of site stabilization

'temporary' camps tend to last a long time

populations seek quick wins ahead of big infrastructure

PRECEDENTS | Corridor

Non-contiguous territory/ infrastructure

translation to value in Palestinian economic reconstruction needs

West Berlin (surrounded by East Germany)

Basel (Mulhouse airport corridor)

Gotthard Tunnel

Kaliningrad (Lithuania corridor)

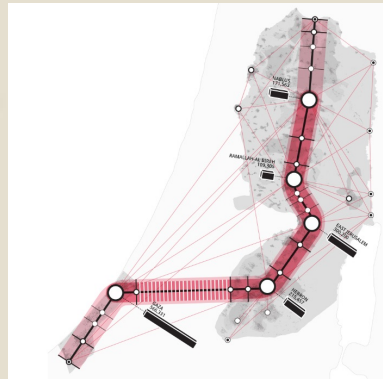
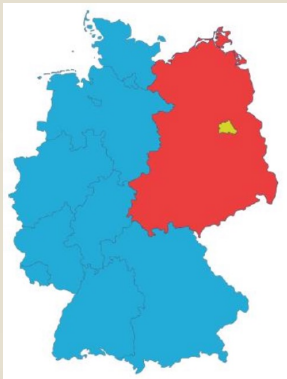

precedents for strategic corridors

PRECEDENTS | Principles

post-conflict / post-disaster recovery

translation to value in Palestinian economic reconstruction needs

plan early

define long-term plan before implementing short-term solutions

work together

coordinate strategies, planning, and implementation

capture quick wins

create identity and increase local engagement

explore range of enabling options

consider alternative financing and delivery mechanisms

build on what has gone before

don't duplicate efforts

FOUNDATIONS | Don't Reinvent The Wheel

MAS	many
World Bank	many
UN	many
Quartet	many
RAND	The ARC + ongoing
PNA	National Spatial Plan
PNA	National Road and Transport Master Plan
The Portland Trust	Global Palestine, Connected Gaza
The Portland Trust	Beyond Aid + 2023 update Forward
Post 9/11 coalition	New York New Visions

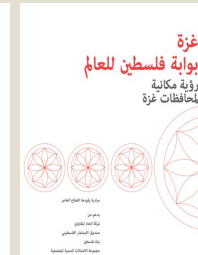

...now at a significant new starting point

ECONOMIC BACKGROUND | GDP Growth

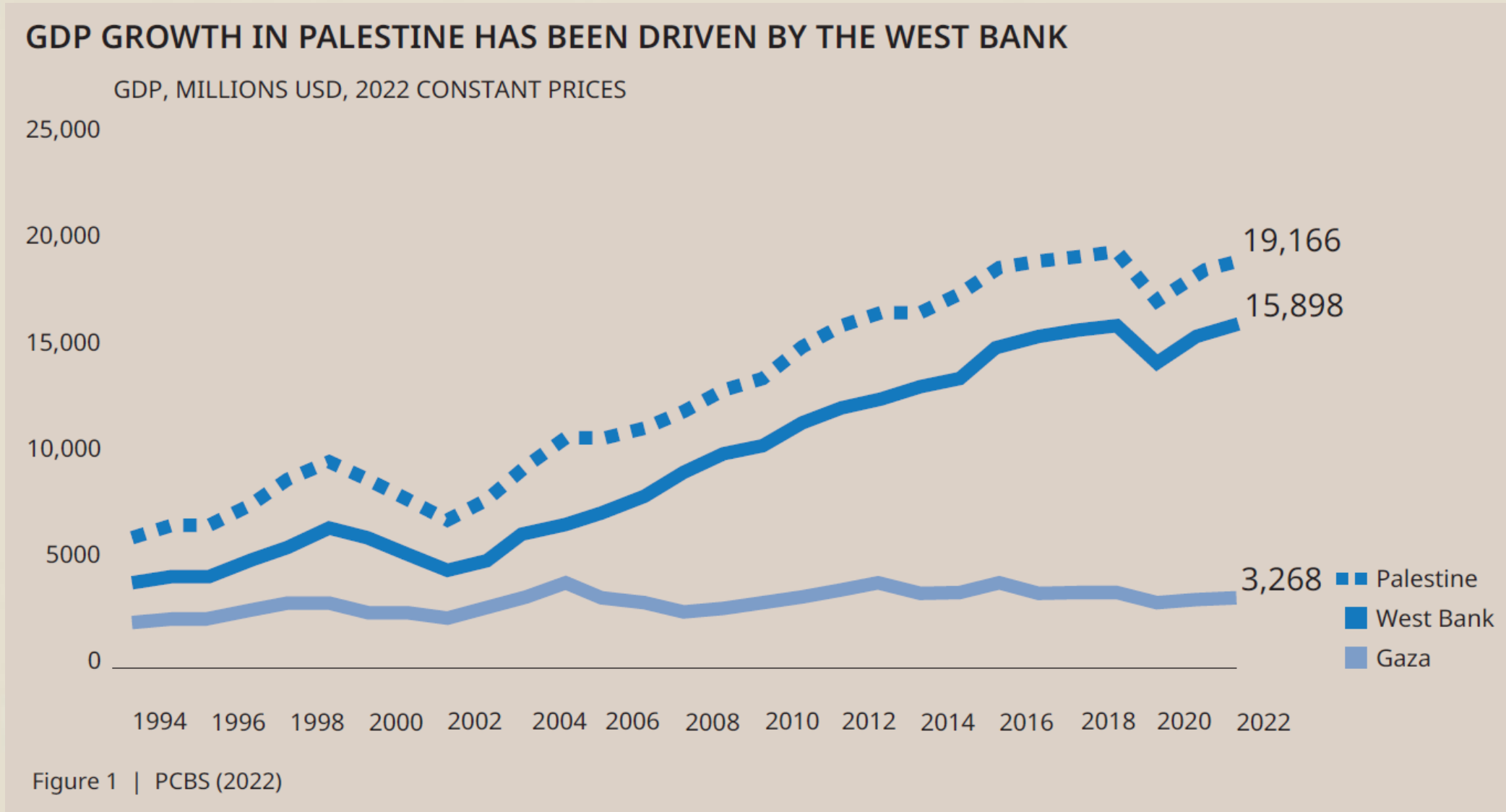

ECONOMIC BACKGROUND | GDP Comparative

GDP PER CAPITA IN PALESTINE TRAILS OTHER REGIONAL ECONOMIES

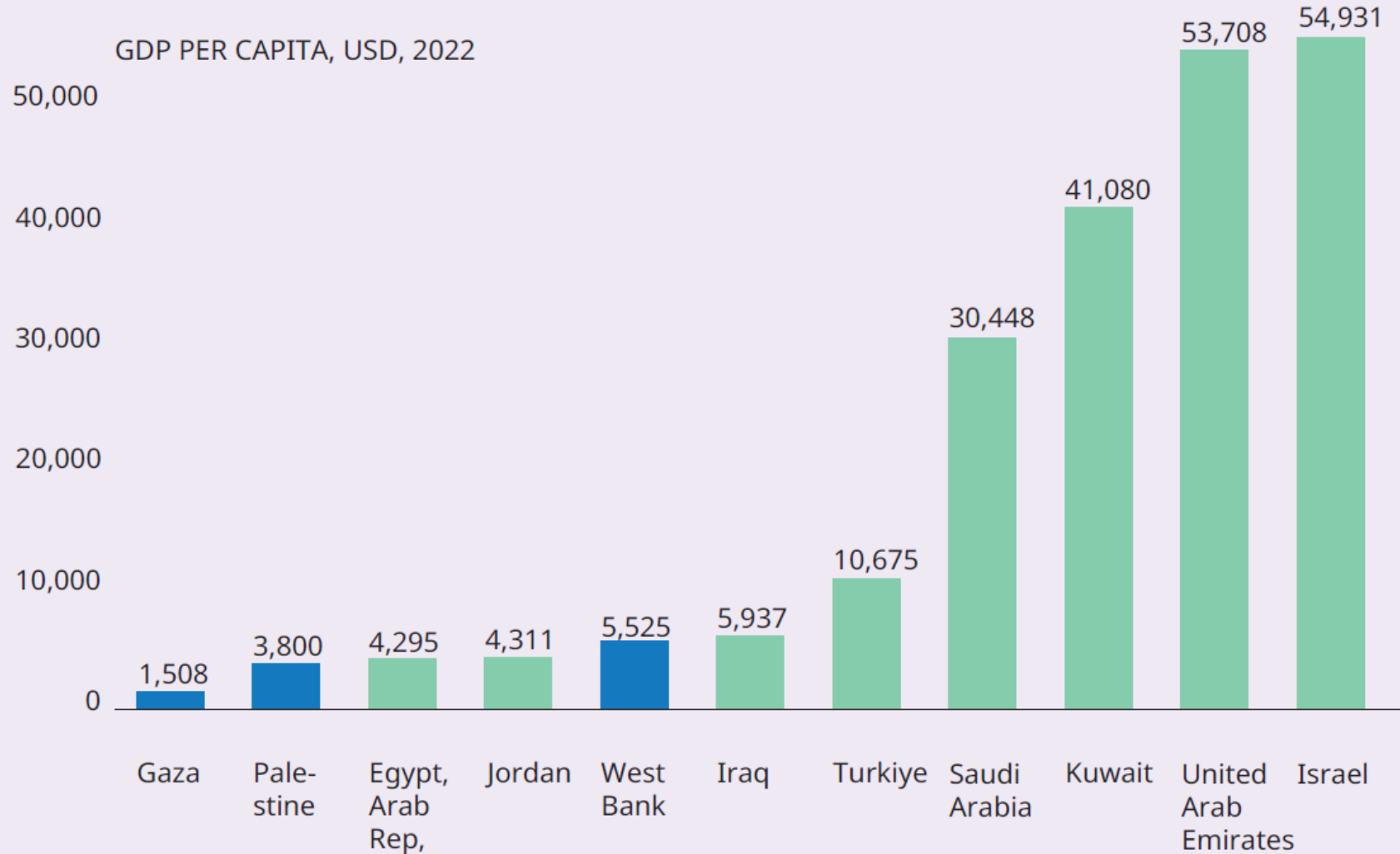
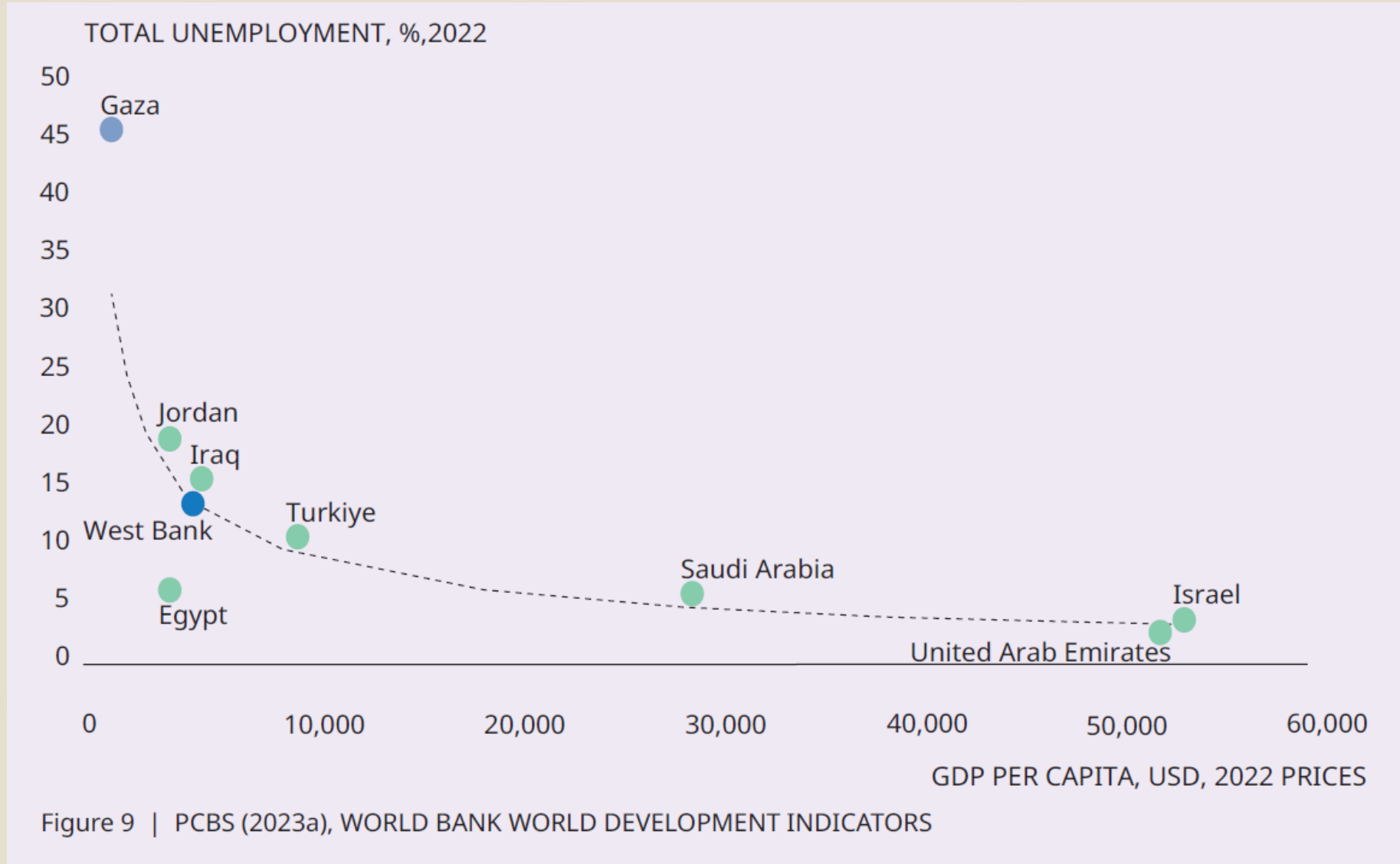

Figure 4 | PCBS (2022), WORLD BANK WORLD DEVELOPMENT INDICATORS

ECONOMIC BACKGROUND | Low GDP, High Unemployment



ECONOMIC BACKGROUND | Growth Scenario, Gaza, Sectors

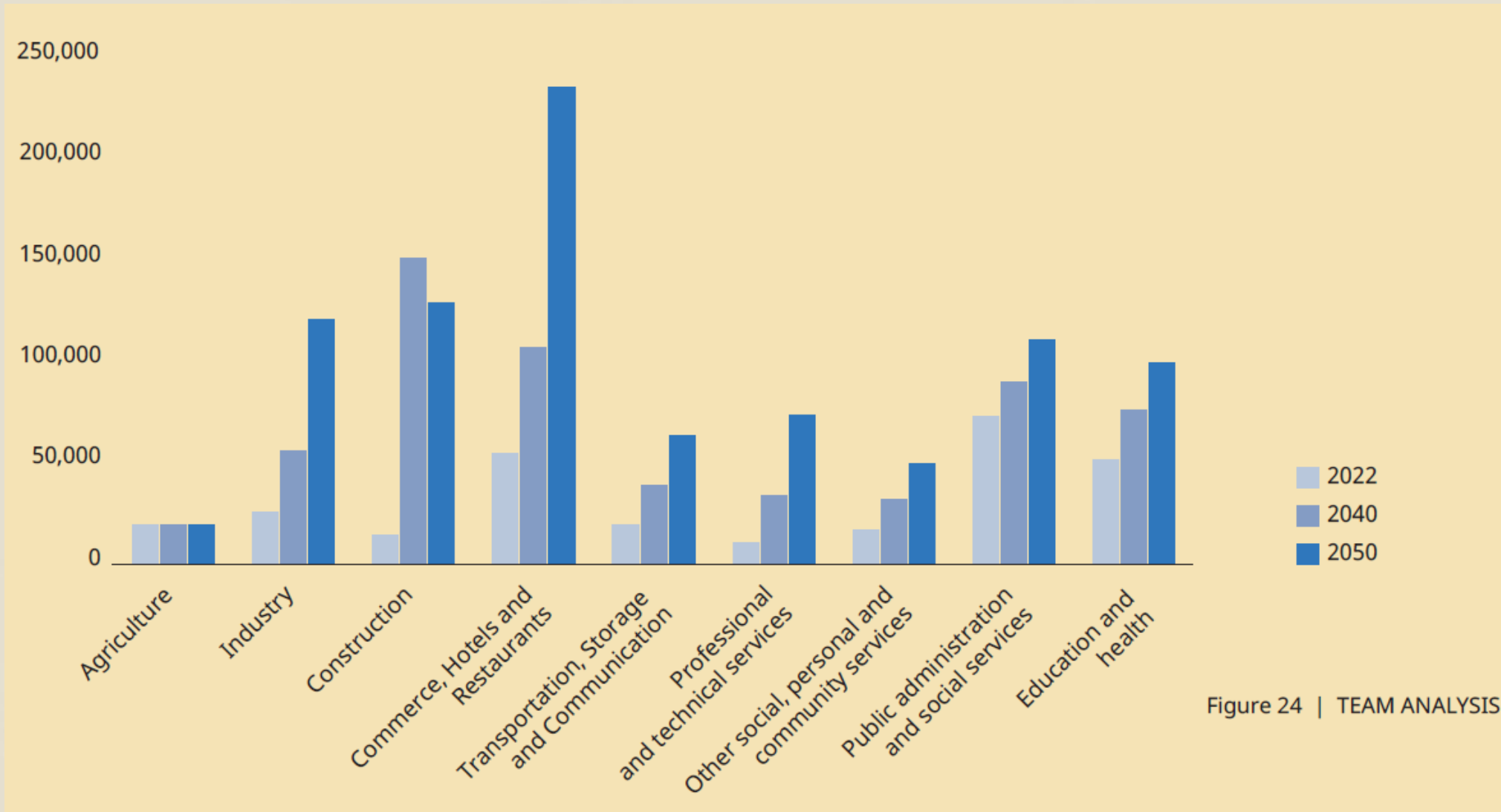
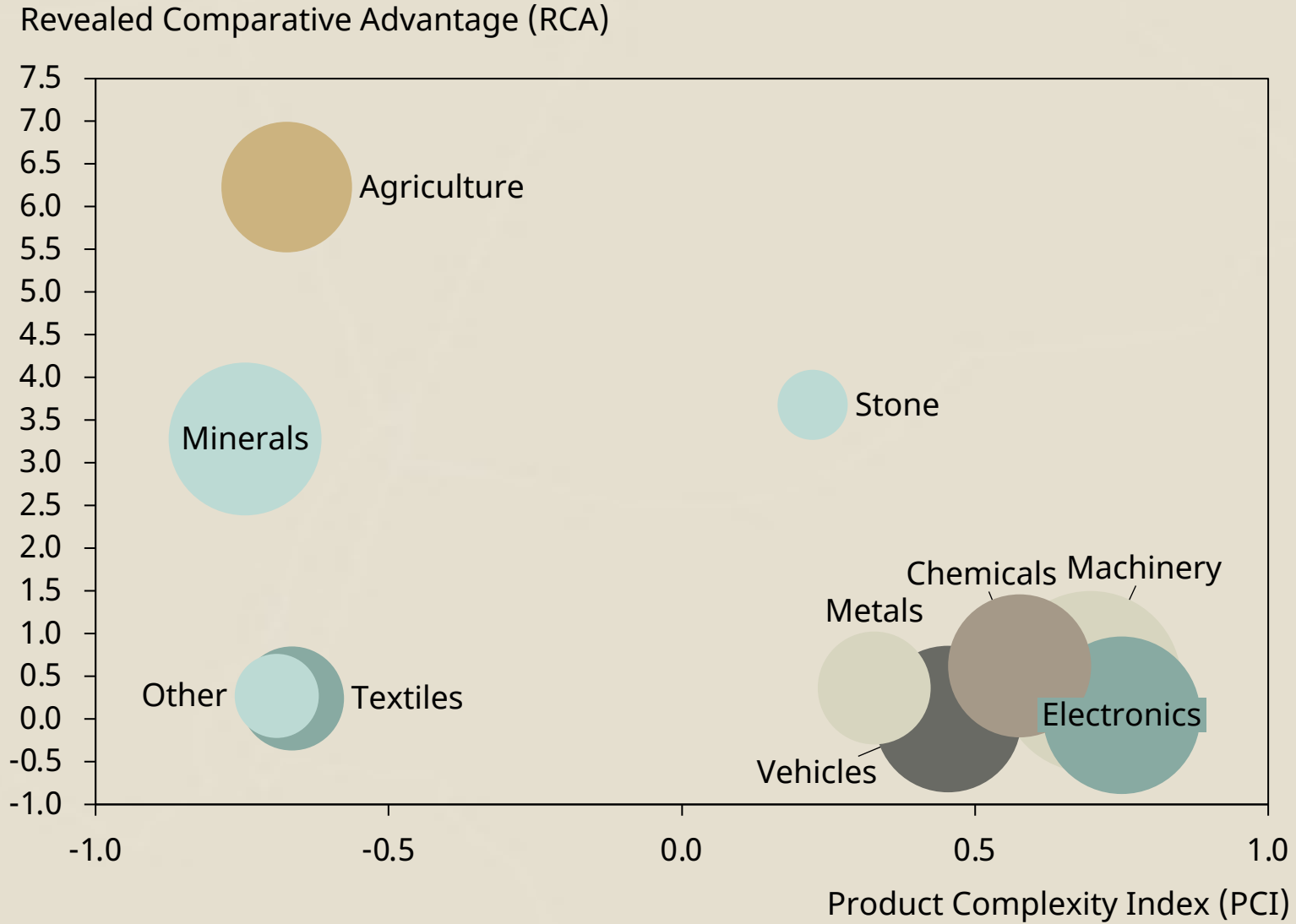
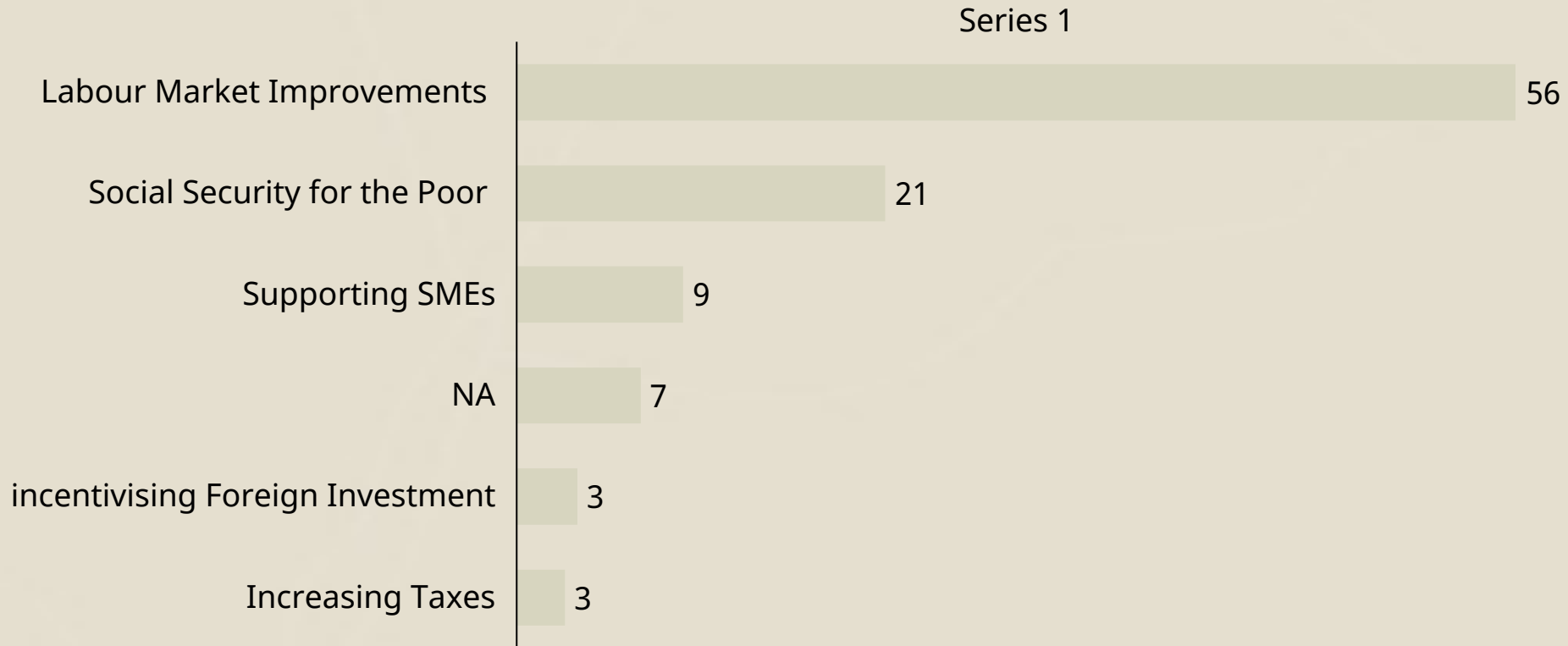

Figure 24 | TEAM ANALYSIS

ECONOMIC BACKGROUND | Trade Opportunities



ECONOMIC SURVEY | Most Important Economic Policy



ECONOMIC SURVEY | Income Inequality is a problem...

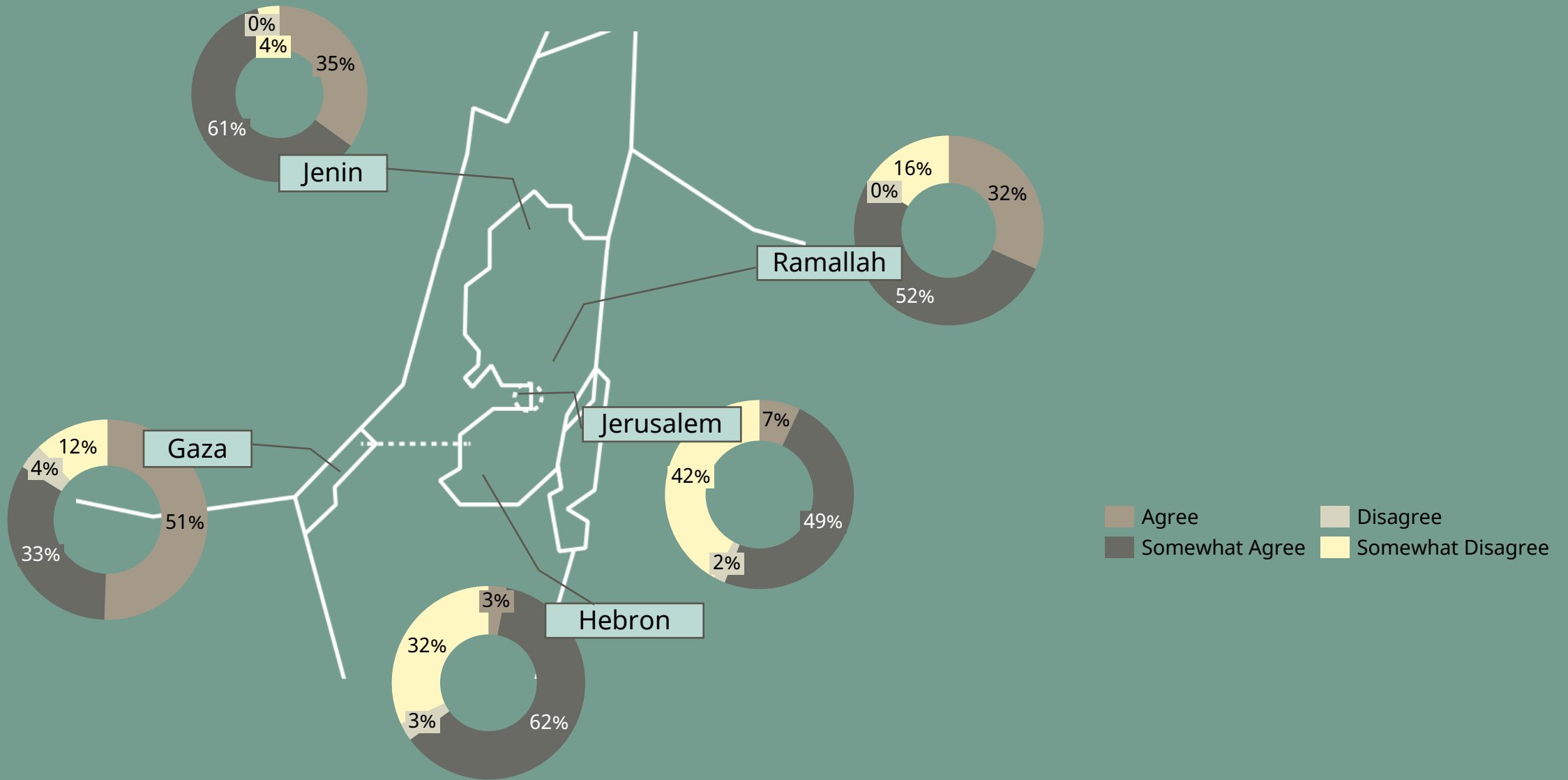

PALESTINE EMERGING

INSPIRATION

foundation assumptions

URBANIZATION

coordinated development

CONNECTIVITY

urban development, movement, corridors

NETWORKS

energy, water, digital

SOCIAL ASSETS

health, housing, education

GROWTH

finance, industrial sectors, regulatory arbitrage

SOFT POWER

culture, creativity, tourism, entertainment

ENGAGEMENT

governance, participation

GAMECHANGERS

INSPIRATION | Best Starting Point

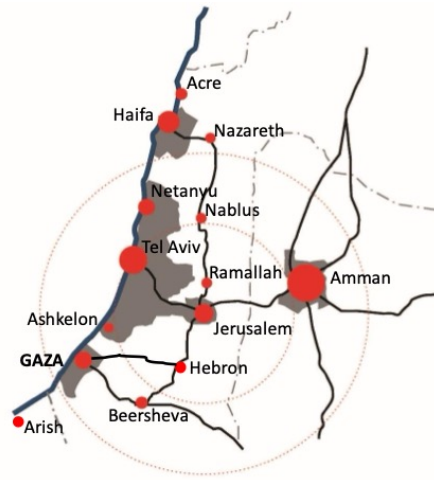
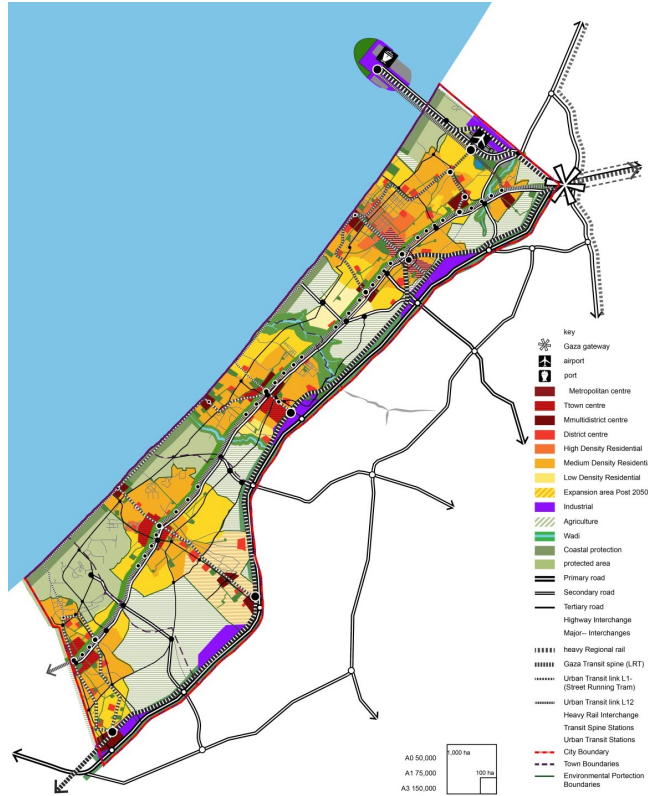

Global Palestine Connected Gaza

INSPIRATION | Best Starting Point



National Spatial Plan

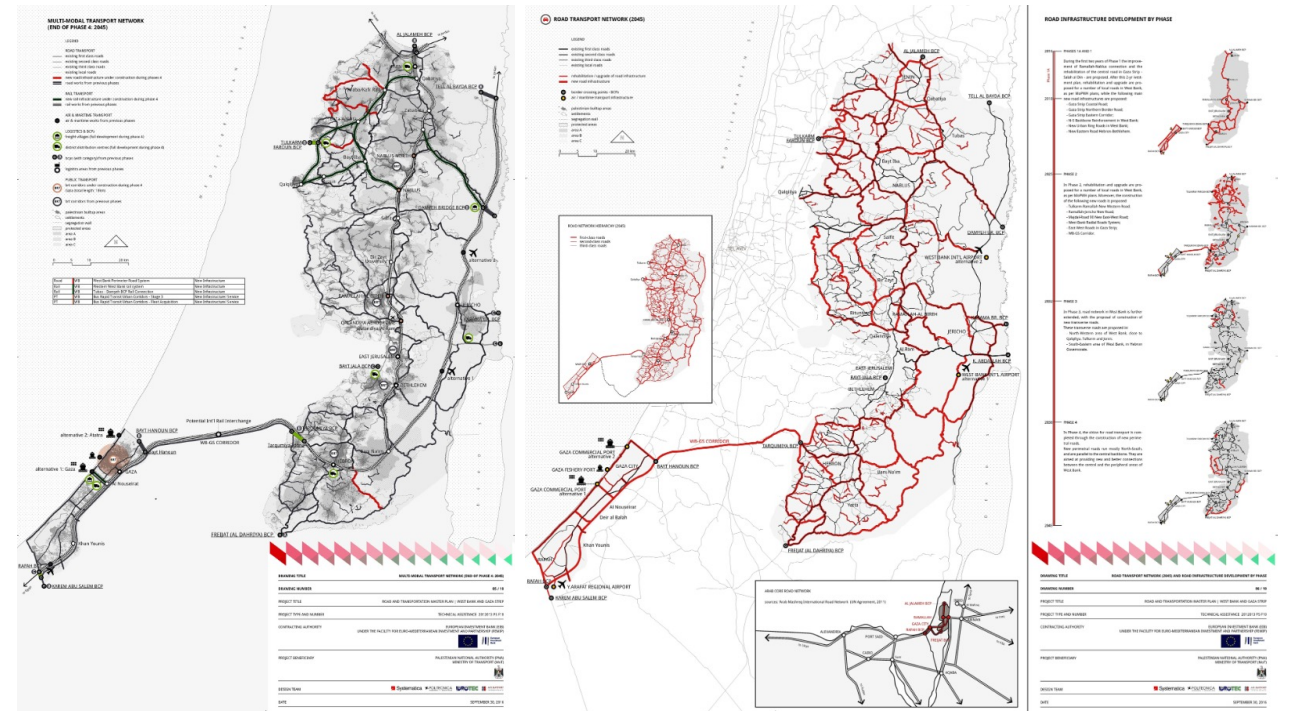

National Road and Transport Master Plan

PALESTINE EMERGING

INSPIRATION

foundation assumptions

URBANIZATION

coordinated development

CONNECTIVITY

urban development, movement, corridors

NETWORKS

energy, water, digital

SOCIAL ASSETS

health, housing, education

GROWTH

finance, industrial sectors, regulatory arbitrage

SOFT POWER

culture, creativity, tourism, entertainment

ENGAGEMENT

governance, participation

GAMECHANGERS

URBANISATION | Facing Into The Debate

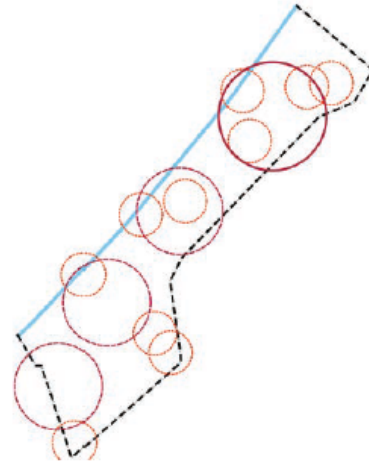
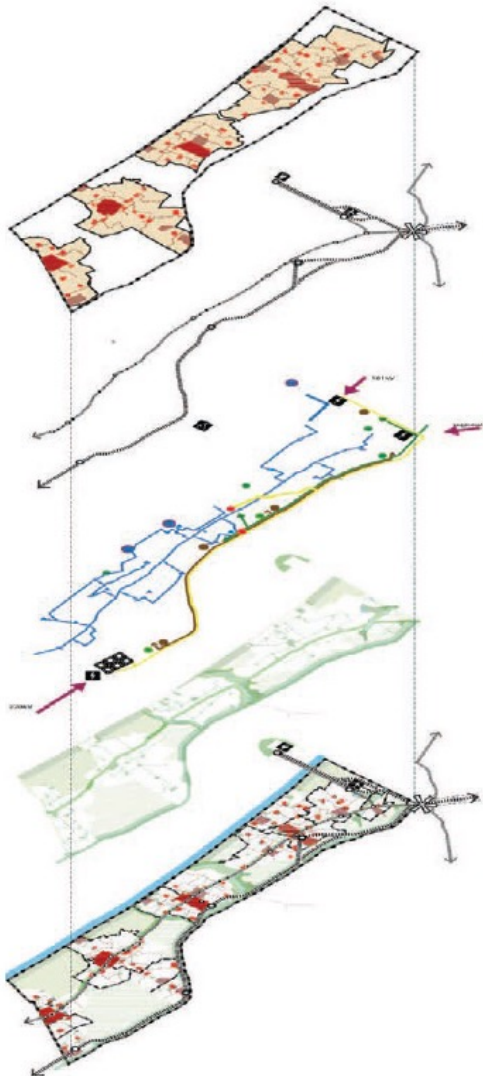

in the right place

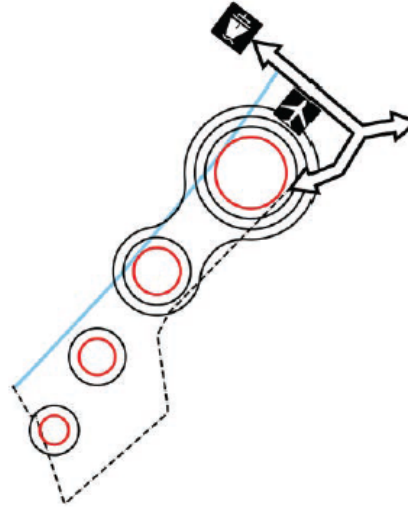

grow to the north

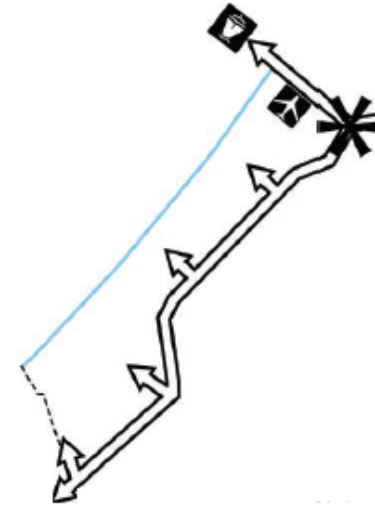

serve from the edge

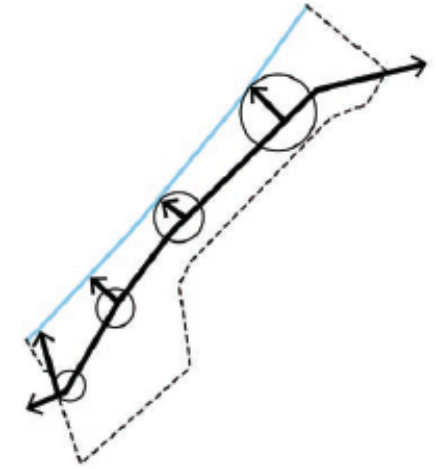

build on history

GAZA

2020	2M	55 residents/Ha
2050	4M	110 residents/Ha

(2020 - NYC 112 residents/Ha)

PALESTINE EMERGING

INSPIRATION

foundation assumptions

URBANIZATION

coordinated development

CONNECTIVITY

urban development, movement, corridors

NETWORKS

energy, water, digital

SOCIAL ASSETS

health, housing, education

GROWTH

finance, industrial sectors, regulatory arbitrage

SOFT POWER

culture, creativity, tourism, entertainment

ENGAGEMENT

governance, participation

GAMECHANGERS

CONNECTIVITY | Short, Medium and Long-Term

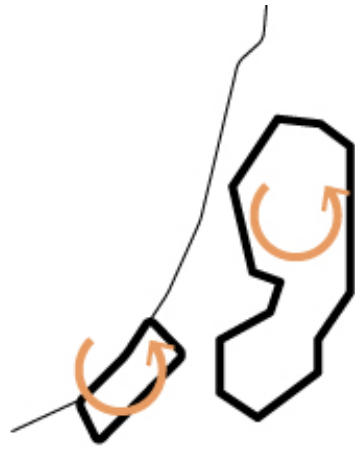

short term
micro-scale

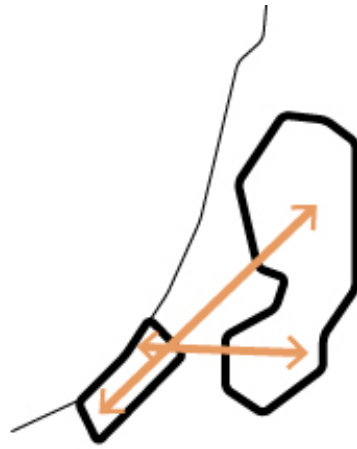

medium term
meso-scale

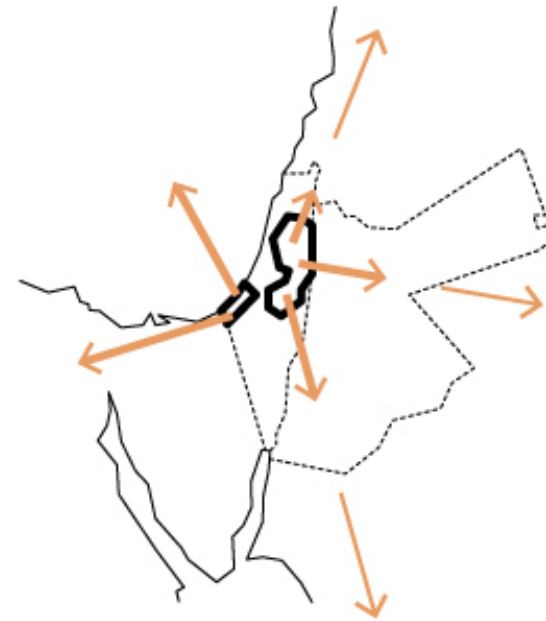

long term
macro-scale

CONNECTIVITY | Consensus Required



Gaza/West Bank link

connect with multi-modal spines

back-bone' spines

rail + road

diffused multi-modal infrastructure

connect disjointed road network

enhance mobility in rural areas

public transport networks

BRT systems

high-frequency services

low-speed infrastructure

cycling highways and pedestrian thoroughfares

knit together communities

moderate demands on road networks

expanded facilities at border crossings

boost freight & logistics capacities

CONNECTIVITY | The Corridor

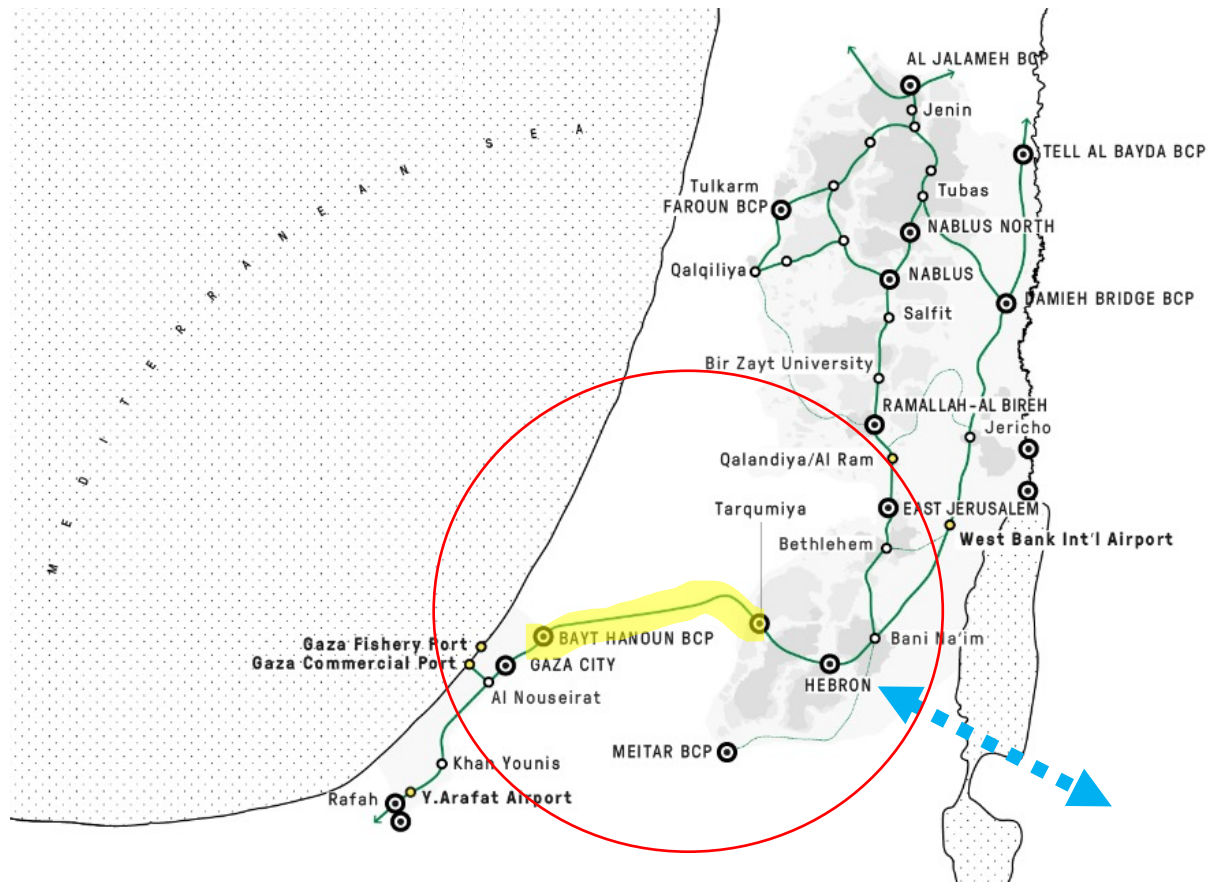

Gaza/West Bank link

Palestinian project but located on Israeli territory
Palestinian exclusive use
Israel to maintain the line and physical right-of-way
link extends with incremental stops into west bank

future regional expansion

potentially connects to Jordan' Saudi, UAE, India



PALESTINE EMERGING

INSPIRATION

foundation assumptions

URBANIZATION

coordinated development

CONNECTIVITY

urban development, movement, corridors

NETWORKS

energy, water, digital

SOCIAL ASSETS

health, housing, education

GROWTH

finance, industrial sectors, regulatory arbitrage

SOFT POWER

culture, creativity, tourism, entertainment

ENGAGEMENT

governance, participation

GAMECHANGERS

NETWORKS | Power

- Requires big investments, electricity demand outstrips supply: to ~1,790 megawatts: 1,360 West Bank and 430 Gaza. Demand up ~3.5% pa, to ~2,342 by 2030
- WB >90% dependent on imports from Israel, remainder from Jordan (~80), small amount domestic renewables, generators. Solar photovoltaic capacity ~159.5
- Gaza Plant generated ~70, Qatar diesel, with ~120 imported from Israel, creating deficit of ~240 (pre-October), therefore 12 hours per day. Solar photovoltaic capacity ~19
- PCBS and MAS forecasts not available for Gaza, although lowest-band of baseline scenario now wrong, being set up to calculate 2 weeks after ceasefire
- Long-term planning for commercially-sustainable power, including Jenin, Zahrat al-Finjan waste-to-energy and Gas for Gaza, to generate ~600, around half Gaza's 20230 needs. Renewables require transmission corridors to connect cheap land to demand
- BESS can support grid and offer smart electricity supply during peak, enhancing stability and sustainability
- Distribution: DISCO transfer needs to be delivered, ending severe and opaque fiscal anomaly, reducing prices
- Gaza Marine represents a decade's very significant revenue opportunity

NETWORKS | Power

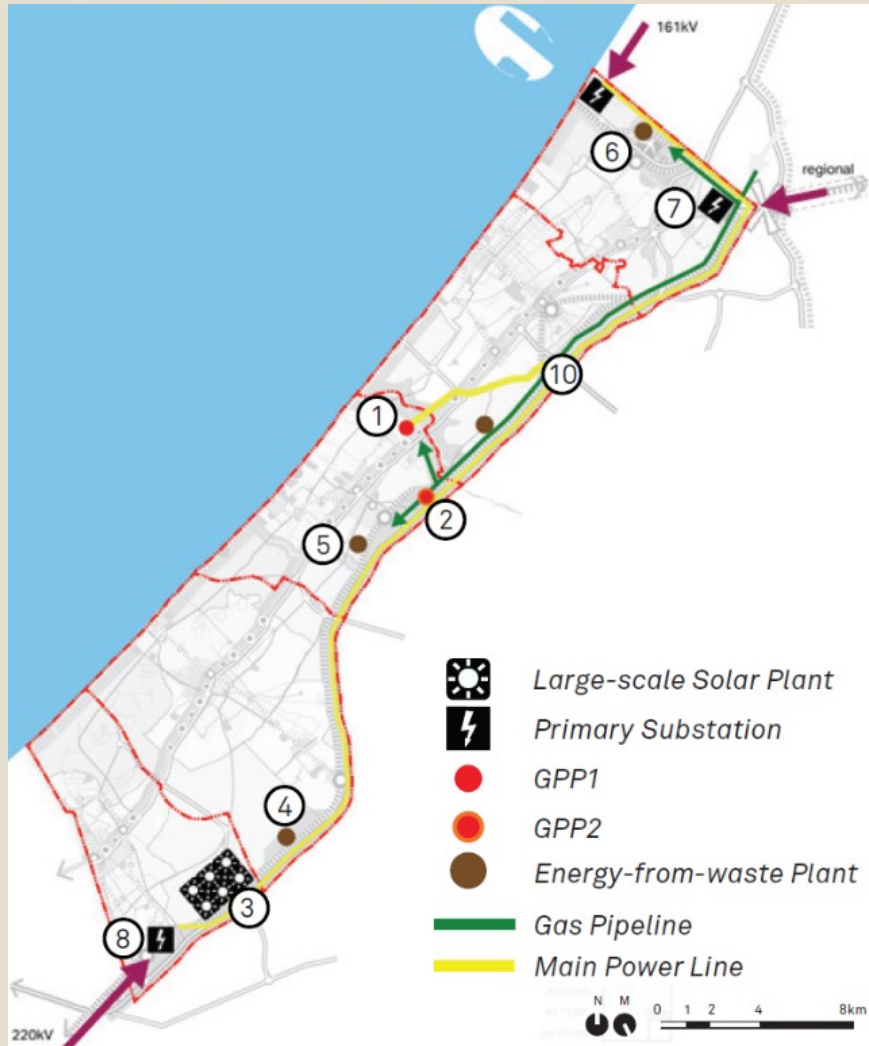

interim energy supply

including provisional links to Egyptian and Israeli networks

Gas for Gaza

Gaza Power Plant gas convergence

increasing capacity for Gaza Power Plant to 560 MW.

independent high-voltage grid

integration with West Bank and regional utilities networks.

large-scale Solar Photovoltaic (PV) plant

West Bank will develop extensive solar farms in Area C

supplement central energy production with package solar PV plants

including innovative local solutions like Virtual Powerplants.

offshore Gaza Marine natural gas field

exporting to Egypt for processing

NETWORKS | Water

- Water in Gaza (pre-October) not suitable for drinking, exceeding limits of chloride and nitrates. 80% Gazans buy drinking water from unregulated water tankers
- Some 440 million cubic metres used in Gaza, of which 300 from aquifers and just 1.7% desalination (doubled in 2022 to ~20). GCDP could produce ~55, also coastal aquifer (Israel extracts 66%, highly-contaminated by sewage and seawater infiltration)
- West Bank: Oslo 1995 cap (118), no Jordan access, wells resold, no construction (~820 demolitions). Shortfall purchased from Mekorot doubled 2030, deficit ~ 171
- V high-levels (37%) water loss, just 36% WB Palestinians daily running water; 92% high-cost rooftop tanks supplied by trucks. 291/557 localities water cuts, 221 no daily water, 49 WB population centres no public water network. High levels dilapidation, pollution, salinity; high prices. V limited supply for agriculture, only 6.8% Palestinian WB cultivated land irrigated, with water shortages also impacting industry and tourism
- Wastewater massive challenge (systematic re-use for agriculture opportunity)
- Gamechanger: massive new desalination plant, leveraging existing regional plans, materials and contracts to meet Gaza's water needs, exporting to Jordan on a sustainable commercial basis and importing excess solar energy to the West Bank

NETWORKS | Water

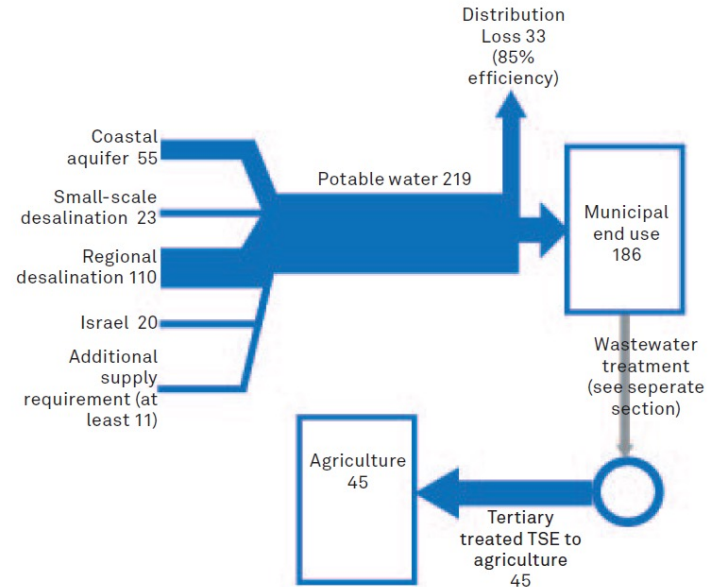

GAZA 2050

water strategy

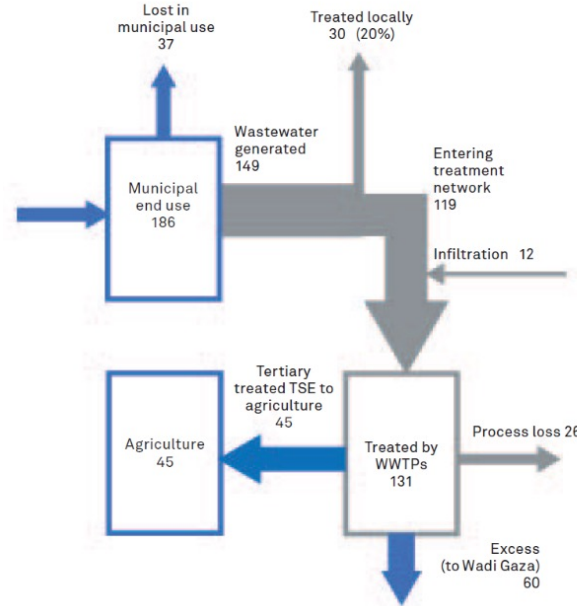

wastewater strategy

repairing existing plants

Kahn Yunis, Deir Al Balah, and Gaza City

centralised regional-scale desalination plant

position Gaza to be a net exporter of water

improve efficiency of networks

grey water for irrigation

educational campaigns/ local enforcement

shut down illegal wells

Territorial Corridor

connect Gaza/WB networks

PALESTINE EMERGING

INSPIRATION

foundation assumptions

URBANIZATION

coordinated development

CONNECTIVITY

urban development, movement, corridors

NETWORKS

energy, water, digital

SOCIAL ASSETS

health, housing, education

GROWTH

finance, industrial sectors, regulatory arbitrage

SOFT POWER

culture, creativity, tourism, entertainment

ENGAGEMENT

governance, participation

GAMECHANGERS

SOCIAL ASSETS | Healthcare Excellence

private-sector healthcare delivery strategy

SHORT TERM: focus on provision of basic, primary care, invest in healthtech pilots

MEDIUM TERM: scale healthtech pilots, restructure secondary and tertiary care facilities, introduce remote clinics

LONG TERM: consolidate private/public health system, standardize digital systems

standardization

modular construction to accelerate neighborhood-scale development

unified healthcare network of nurse practitioners

centralized, digital patient record system

telehealth platform

regional doctors to provide specialized consultations to patients unable to access healthcare facilities

quality healthcare education via hospital placements

exchange programs with regional hospitals.

national health insurance system

staggered pricing system to ensure that vulnerable can gain adequate access to healthcare

SOCIAL ASSETS | Community Housing

HEALTHCARE EXCELLENCE

COMMUNITY HOUSING

phased approach

SHORT TERM: focus on occupancy assistance and establishment of secure environment

MEDIUM TERM: transition into more permanent housing solutions

LONG TERM: neighbourhood development, expansion of urban boundaries surrounding community hubs

legal and financing mechanism

resolve land disputes before any development starts

financing arm as part of PBRD to support the acquisition of land

value capture for original land owners

train local workforces in modular manufacturing

provide jobs and economic development

supply and manufacturing chain within Palestine

smaller urban apartments

meet demand of younger and more independent populations

low-interest financing products and subsidized upfront investments

accelerate community development.

SOCIAL ASSETS | Next-Generation Education

HEALTHCARE EXCELLENCE

COMMUNITY HOUSING

NEXT-GENERATION EDUCATION

phased approach

SHORT TERM: rebuild educational assets

MEDIUM TERM: pilot new curriculum

LONG TERM: develop academic center of excellence

educational assets

organized around community centers

hybrid/digital curriculum modules

for students in remote areas

MOOCs integrated into existing curriculums to supplement local programs

curriculum pivot to include including coding

prepare students for employment in a 5g/ ai enabled economy.

research cluster for reconstruction

train local students on reconstruction related skills

business administration and public policy

train and educate future leaders

global partnerships and mentorship network

expose Palestinian students to a global perspectives

translate more foreign language books into Arabic

breach language barriers and introduce new thinking

PALESTINE EMERGING

INSPIRATION

foundation assumptions

URBANIZATION

coordinated development

CONNECTIVITY

urban development, movement, corridors

NETWORKS

energy, water, digital

SOCIAL ASSETS

health, housing, education

GROWTH

finance, industrial sectors, regulatory arbitrage

SOFT POWER

culture, creativity, tourism, entertainment

ENGAGEMENT

governance, participation

GAMECHANGERS

GROWTH | Sectors

- Unemployment rising from 14.3% in 2000 to 23.4% in 2022
- Labour force participation 45%
- Jenin (4.8k businesses) 91% drop productive capacity, 96% report sales drop
- Nablus (9.5k) 90% decrease purchasing power, 8% business property damage, average sales decline 57%
- Ability of private sector to attract more capital
- Move away from low-productivity activities
- Construction leading sector domestically in coming years, radically accelerated if supply of building materials into Gaza is freed up
- Other support activities around finance, commerce and retail
- Medium-term economic prospects highlight health, tech and tourism for best overall strategic sectoral return on investment

GROWTH | Tech

- Small but dynamo potential
- Developed telecoms
- Early-stage start-up ecosystem
- Credible IT outsourcing space
- Educated population, skilled workforce, geographic proximity to key markets, linguistics
- Limited access to overseas markets, foreign investors, VC
- Low awareness among buyers
- Mentors for Palestinian founders

- Financial instruments to incentivise international presence (PRI) and derisk outsourcing contracts
- Leverage Palestinian diaspora to help build a global niche tech hub for Palestinian tech capabilities
- prioritizing obvious glidepath through high-value Gulf, use of Arabic, sources of capital, 5G boost
- Incubate highly specialized tech clusters, glidepath to business models in next gen AI, 6G
- Robust regulatory framework to attract investment, e.g. facial recognition, Halal Digital use cases
- High value add sector to accelerate economic development journey from agrarian to industrial

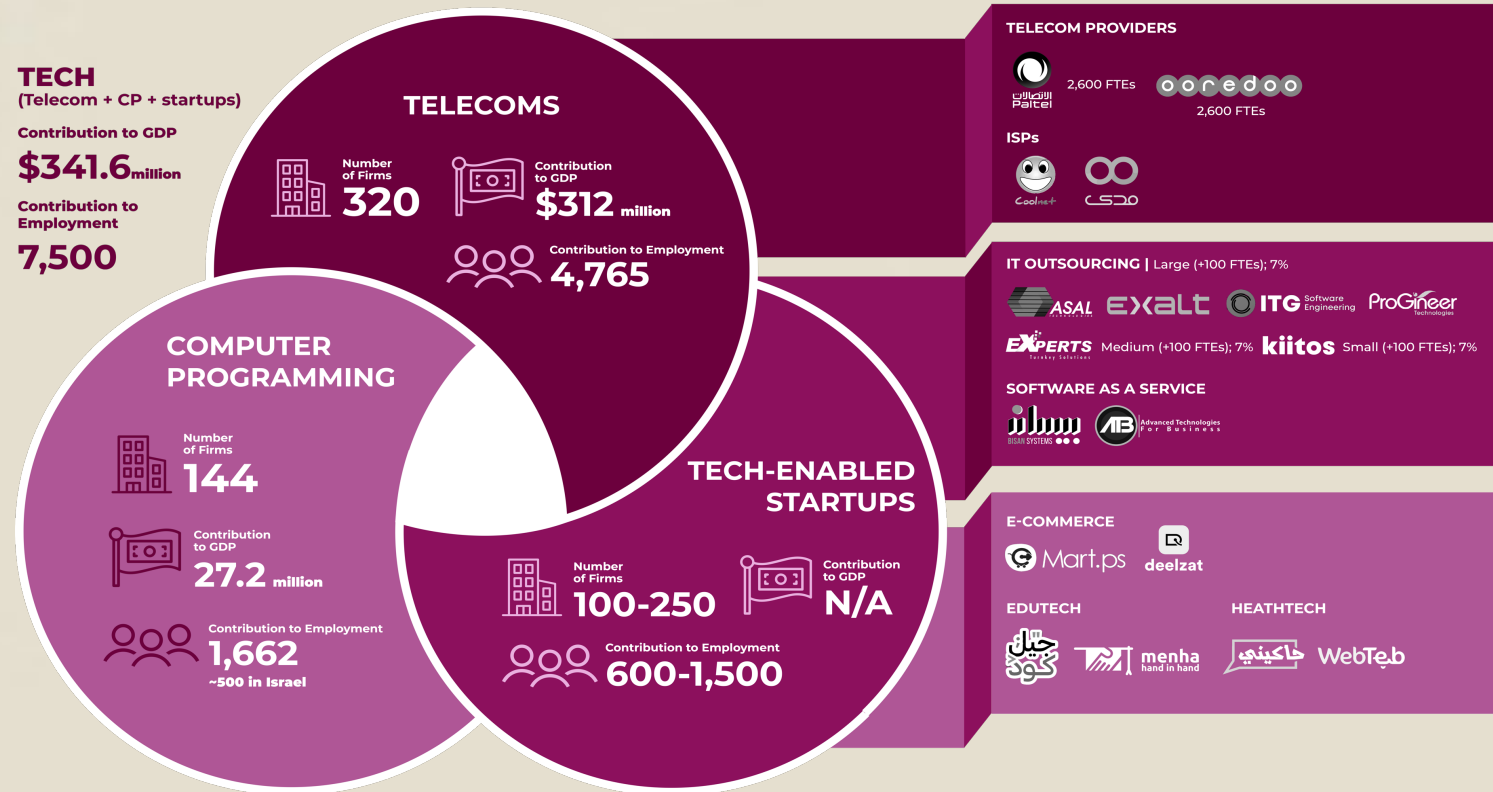

GROWTH | Tourism

- Challenges include safety perceptions, restrictions on the movement of people
- However, massive potential to help drive small businesses and job creation (40k jobs, 2.8% GDP)
- Assets of enormous global relevance: Bethlehem, Jericho globally known brands
- 80% international tourists religious pilgrims, investment to increase nights and spend
- Significant flows of Palestinians from Israel and Jordan
- Emerging “ESG” tourism segment: wealthy young adventurers who factor in social justice, authentic culture, economic development and sustainability to their locational decision-making, have a significant longer-stay component
- Less reliance on hotel, food and ancillary product Palestine competes poorly on
- Digital targeted communication key, learn from best national tourism operators
- Summer schemes for diaspora, museum restoration and system components

GROWTH | Trade

- Imports over \$8b 2022, outweigh <\$2b exports, creating very high trade deficit. Even if smooth internal market, Palestine very small, domestic, inward-looking economy
- Trade is central requirement for growth, job creation and modernisation. Requires dehampering of restrictions and medium-term free movement of goods externally
- Unrestricted export arrangements substantially amplify access to markets, bolster export-oriented industries, and attract foreign investment, bespoke goodwill leveraging EU, US trade agreements, as well as Arab world (~500m customers). “Made in Palestine” brand emphasising trade over aid. Several alternative customs union options to explore
- Low productivity prevalent across economic sectors, so companies must become more competitive, incl through building export capabilities, incl to specific preferences and requirements of target foreign markets and product and pricing strategies
- Cash and credit issues of being tied to Shekel underpinning macroeconomic weakness and fiscal drag, whereas benefits of alternative monetary arrangements are significant if at least as robust internationally and on solid reserves basis. Leverages customs options
- Common standards across Gaza and the West Bank third leg of stool, with carefully constructed, supported and navigated arrangements representing step-change and new paradigm for Palestinian economy. Requires very significant institutional capability and technical assistance

PALESTINE EMERGING

INSPIRATION

foundation assumptions

URBANIZATION

coordinated development

CONNECTIVITY

urban development, movement, corridors

NETWORKS

energy, water, digital

SOCIAL ASSETS

health, housing, education

GROWTH

finance, industrial sectors, regulatory arbitrage

SOFT POWER

culture, creativity, tourism, entertainment

ENGAGEMENT

governance, participation

GAMECHANGERS

Soft power | Leverage

PERSUASIVE APPROACH TO INTERNATIONAL RELATIONS

create uplifting post-crisis brand to shape an overall narrative

messaging strategy and key visuals as a quick early nation branding exercise
tourism marketing campaign aimed at dedicated target groups in selected markets

restore historical and cultural sites in Gaza and the West Bank

consider cultural development precedents in Italy and France
ensure accessibility, create interpretation centers and education programs

launch a Palestine Film Strategy

streaming-compatible mini-series/ telenovela (role model: South Korea).

host National Expo as a 3-4 month long event on reclaimed land of future Gaza Port Island

highlight themes related to cultural reconnection
exhibitions/ pavilions to showcase related projects

support and boost creative industry as a major theme in the region

create studio districts with subsidized spaces for creative activities
develop environments in the metaverse and other virtual worlds (leveraging 5G connectivity)

Palestine tourism initiative

develop industry-scale tourism for both Gaza and the West Bank by promoting relevant sites and destinations
prepare an enabling and quality training program for small hotels & inns

PALESTINE EMERGING

INSPIRATION

foundation assumptions

URBANIZATION

coordinated development

CONNECTIVITY

urban development, movement, corridors

NETWORKS

energy, water, digital

SOCIAL ASSETS

health, housing, education

GROWTH

finance, industrial sectors, regulatory arbitrage

SOFT POWER

culture, creativity, tourism, entertainment

ENGAGEMENT

governance, participation

GAMECHANGERS

ENGAGEMENT | On The Ground

EMPHASIZE CIVIC ENGAGEMENT IN THE RECONSTRUCTION PROCESS

work with civil society groups and leaders

leadership development programs to build capacities for strategic collaborations with international agencies

anchor projects rooted in community and family networks

prepare local communities and for activities related to reconstruction

promote youth engagement programs

online and in-person initiatives to encourage civic engagement and enhance employability and personal branding

training for freelancing, volunteering, and participation in community projects

shadow board in the agency for reconstruction to ensure youth participation.

professional and investment training

attract local and international investments

retrain and leverage Palestinian diaspora and international volunteers

pro-bono legal workshops

educate local communities on legal processes and rights

navigate business and land acquisition challenges during reconstruction

enhance legal literacy and empowerment

ENGAGEMENT | Initiatives

EMPHASIZE CIVIC ENGAGEMENT IN THE RECONSTRUCTION PROCESS

PLATFORMS

'Agency for Reconstruction with Changes'

over-arching interdisciplinary ministry responsible for overseeing reconstruction

'Covenant of Mayors'

formal agreement among local governorates

emphasize crucial role of local governance in the developmental process

'Citizen Assembly' platforms

digital platforms/ managed through pre-agreed protocols

'Palestinian Diaspora Network'

attract Palestinian diaspora to engage them with Palestine-related affairs

offer mentorship and networking component, pairing diaspora with local Palestinians

'Visit Palestine' initiative – oriented towards diaspora youth

'Womens Club'

secure forum to enfranchise women and young family members

incentivize participation in community planning and the broader reconstruction process

create a global mentorship program for local women leaders

ECONOMIC RECONSTRUCTION AND GROWTH

20 MAY 2024

PREP

the work done so far

THE PLAN

what is it ?

GAMECHANGERS

where we are now

NEXT STEPS

what do we want from you

GAMECHANGERS |

Multipliers and Enablers

- Embedded at the heart of “Palestine Emerging” are a series of “Gamechanger” interventions
- The nature of these vary, including key infrastructure, macroeconomic, connectivity and community plays
- What they have in common is scale to radically change the outcomes path for the West Bank and Gaza economy
- If delivered, they will have a disproportionate effect, acting as multipliers and enablers to greater economic activity, jobs, household wealth, exports, connectivity and GDP
- Economic value has been modelled as a base case (pre-October) and a growth case (Gamechangers) to 2050
- The Gamechangers include telehealth and the sector, a deep-water port, a global technical university of reconstruction based in Gaza, 5G and the Palestinian Bank of Reconstruction and Development

GAMECHANGERS

GAMECHANGERS

Massive New Desalination

Industrial Port

Gaza/West Bank Link

Extensive 5G

Technical University of Reconstruction (TUR)

Telehealth Platform

Palestine Bank of Reconstruction and Development

Trade, Currency and Standards Pivot

Palestine Bond

Classification

Networks

Networks

Networks

Networks

Social Assets

Social Assets

Growth

Growth

Soft Power

Geography

Gaza + WB

Gaza

Gaza + WB

Gaza + WB

Gaza + WB

Gaza + WB

Gaza + WB

Gaza + WB

Gaza + WB

Timeframe

short/med

short/med

short/long

med/long

short

short

short/long

med/long

short/med

GAMECHANGERS

Massive New Desalination

Classification
Networks

Geography
Gaza + WB

Timeframe
short/medium

Meet massive short-term needs/requirement for power

Produce 400mcm of water for own requirements (as well as 2x 55mcm facilities in plan)

Investment in centralized desalination network

Repair and (re)construction

Gas for Gaza

Long-term: leverage pricing arbitrage

price of water in Jordan is high

leverage low renewable energy prices in Jordan to import energy to PENRA West Bank at a discount

Utilise existing architecture of Water Carrier reversal

Regional trade, investment, peacemaking

positive economic dependency

access to cheap water supply: support recovery of natural systems in Jordan

accelerate peacemaking effort within the entire region

sustainable business case to boost bilateral and multilateral funding and cement economic relationships

GAMECHANGERS Industrial Port

Classification
Networks

Geography
Gaza

Timeframe
medium

deepwater port at the northern end of Gaza
offshore location
minimized dredging
decreased impacts to beach environments

Port Island

logistics areas for containerised shipping
LNG terminal
cruise-ship berths
commercial marina
recreational park

integrated industrial zone

linked to high-capacity road and rail alignments
airport logistics zone
Gaza/WB Corridor

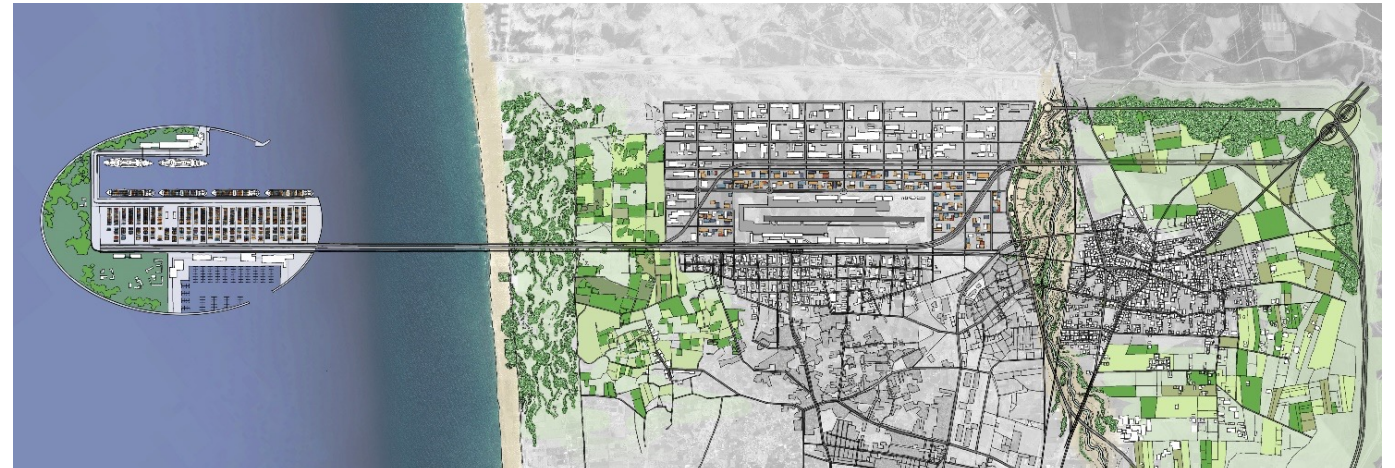

GAMECHANGERS

GAMECHANGERS Gaza/West Bank Corridor

Classification
Networks

Geography
Gaza + WB

Timeframe
short

dedicated link between northern Gaza and southern West Bank + northern Gaza transport hub
enable movement of goods and eventually people

established over phases

SHORT TERM supervised humanitarian (primarily food, medicine) / bonded containers on convoys on roads
MEDIUM TERM cargo on segregated road or rail, tunnels vs high-speed mag-lev
LONG TERM passengers and cargo / domestic travel scheme / free movement without border controls

Palestinian project

located on Israeli territory, for exclusive use by Palestinian entity
Israel will not control traffic but will maintain line and the physical right-of-way
provisions for potential intermediate stop / potential node for a future common economic zone
extension with incremental stops into the West Bank

future regional expansion

connection to Jordan, Saudi, UAE via IMEC

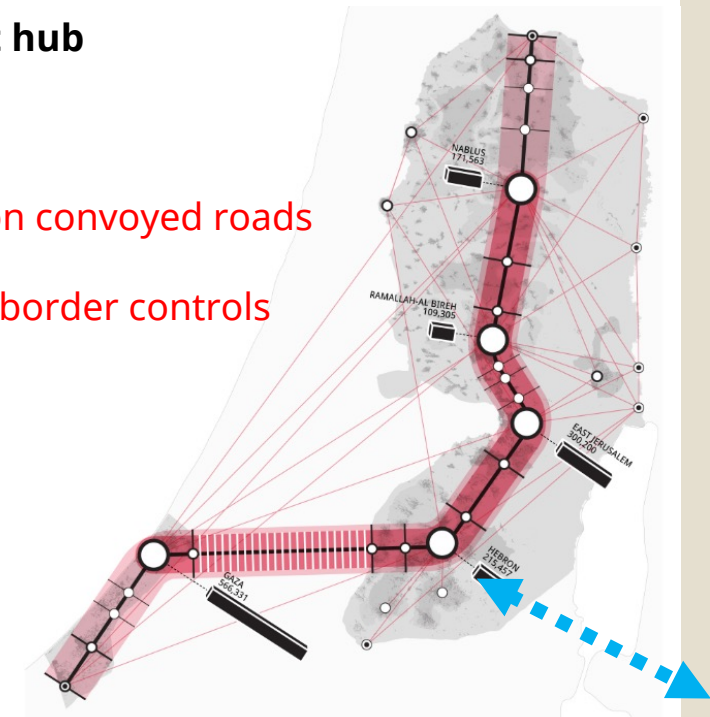

GAMECHANGERS Extensive 5G

Classification
Networks

Geography
Gaza

Timeframe
short

5G as a progression from 2G (Gaza) and 3G (WB)

reliable high-speed bandwidth

benefit areas of higher traffic including urban areas / special locations such as hospitals and schools

match current 4G then 5G upgrade

stabilization efforts

assist reconstruction personnel

allow patients to access tele-health systems / link to regional doctors, specialists, and diagnostic services

support for temporary camps and housing

access to remote-learning systems/ Massive Open Online Courses (MOOCs)

application

Gaza: 5G towers spaced approximately 1.6-5Km apart / total of 100-150 towers communicating with each other

additional mesh network to maintain local and regional connectivity if international connectivity is interrupted

high-capacity microwave: 20-30KM with line of sight/ offers connectivity without physical transit

GAMECHANGERS

Technical University of Reconstruction (TUR)

Classification

Social Assets

Geography

Gaza + WB

Timeframe

med/long

first purpose-built institution of its kind

focused on post-conflict reconstruction

geographically located at the core of best-known identity-based conflict area

anchors a new mixed-use quarter of a regenerated area of northern Gaza

organized around distinct themes

social/economic well-being

governance/participation

security

justice/reconciliation

vocational track

training local workforce to address post-conflict reconstruction

ordinance clearance, built-hazard removal, environmental remediation, and family reconciliation

work alongside national and international aid agencies

creates informed and capable human capital rather than global development jobs

future export services specialism

GAMECHANGERS Telehealth Platform

Classification
Social Assets

Geography
Gaza + WB

Timeframe
short

modern, tech-enabled healthcare infrastructure

supported by 5G connectivity
integrates public and private health systems
addresses needs of disadvantaged and serves remote regions

Gaza healthcare recovery strategy

overcomes initial shortage of doctors and equipment
allows for remote diagnostics and treatment

integration with other systems

centralized, digital patient record system
standardization across Palestinian areas
access to regional networks

GAMECHANGERS

Palestinian Bank of Reconstruction and Development

Classification

Growth

Geography

Gaza + WB

Timeframe

short/long

dedicated, independent, financial development vehicle

Palestinian-led, of international finance partners / high standards of security, accountability and transparency
aligns major institutional funding flows by international community to support Palestinian capacity
maximise positive long-term strategic impact

fund and support core infrastructure projects

raising capital from a mix of global DFIs leverage in private sector donors through risk mitigation
risk review of infrastructure projects business case and management
platform to coordinate investment and funding from international agencies
standardized fund raising, project identification, packaging, investment and post investment asset management

local capacity building

advisory and technical assistance / drawing from institutional capabilities of donors and funders
import substitution / selecting and training local talent to fulfill technical roles vs. expats
nurturing talent for the broader banking ecosystem

GAMECHANGERS

Trade, Currency and Standards Pivot

Classification

Growth

Geography

Gaza + WB

Timeframe

med/long

new paradigm for Palestinian economy

more ability to coordinate key macroeconomic factors
stronger long-term sustainable economic growth base-case
common standards across Gaza and the West Bank

free external movement of goods

export-oriented reform of existing customs union arrangements
open internal market within and between Gaza and West Bank
own management of tariffs, tax and trade agreements

reform monetary framework

alternative arrangements to deal with shekel-related cash and credit crisis
exploration of alternative monetary arrangements
robust reserves base
ability to leverage customs options
technical assistance and enhanced institutional capabilities

GAMECHANGERS Palestine Bond

Classification
Soft Power

Geography
Gaza + WB

Timeframe
short/med

engage diaspora groups

align actions with identity and purpose of Palestine
appeal to wide range of Palestinian diaspora groups

financial vehicle, supporting economic growth

crowd financing platform
support economic and infrastructure reconstruction
patient capital for investment
generate guarantees and stable long-term return on investment

create uplifting post-crisis brand

appeal to progressive themes
combine with large-scale summer schemes and tailored 'Visit Palestine' programs
invest in cultural and enabling projects
focus on cultural themes e.g. heritage and religious site restoration, education, and creative sector

PBRD | Example of taking forward a Gamechanger

- Elaborate the vision of PBRD as a critical enabler, especially of large long-term infrastructure projects, also of major shorter-term reconstruction, to signal serious, strategic and sustained global commitment to a big reconstruction and development program – and coordinated efforts
- Two streams of consultation, Ramallah-based of Palestinian stakeholders and Washington-based of US and global finance institutions, feeding into design for dedicated, independent structure
- Fleshing out of 12-month work programme to develop fully-fledged institution, with best-in-class transparency, accountability and oversight, so has full confidence of key institutional donors and the international community, expressed with equity, maximising investment
- Develop capability parameters and reach out to assemble small team to take forward 12-month delivery plan to invest, at risk, in development of PBRD mandate, structure, priorities, processes
- Palestinian-led and closely integrated with broader Palestinian economic planning and frameworks, to co-invest and support, building capacity on the ground incl technical assistance
- Required capabilities include access to and familiarity with key international and other donor institutions, in US, Europe and Gulf, team to include secondees from major institutions

THE CORRIDOR | Second example: West Bank / Gaza Link

- **Economic necessity:** There is no possibility of sustainable economic reconstruction or long-term growth for the West Bank and Gaza without a physical connection between them
- **Negotiated:** The Corridor was a feature of every negotiation between the parties from Oslo to 2008, when versions of a land lease agreement and exclusive arrangements were set out and initialled by both the Palestinian President and Israeli Prime Minister under US auspices
- **Precedent:** Such a corridor exists today between Russia and its non-contiguous Kaliningrad sovereign territory, crossing the NATO and EU countries of Poland and Lithuania. Even in these times of the war in Ukraine, Russia is able to transport troops and nuclear material through it
- **Vital statistics:** Building on earlier plans, this ~25-mile route would be point-to-point, sealed through mechanisms deemed secure by Israel (est security costs ~\$200m) and take ~9 years to build, of which the first 3-4 will be planning and statutory process, as well as land appropriation
- **Economic centrality:** The Corridor will be a central artery for the free movement of goods and people between the West Bank and Gaza, opening up Gaza port, connecting Egypt with the Arab world East of the Jordan Valley and joining IMEC, the India Middle-East Europe Economic Corridor

THE CORRIDOR | 12 Month Development Plan

- Heads of terms are being developed for a 12-month plan that can **deliver a detailed and viable blueprint for the delivery of the Corridor**, with accurate costings, scheduling and resources
- The main component is a **major tender for a global engineering and design consultancy** to first optioneer (~4 months) the most viable mode, such as train, tunnel and raised highway, and then (~6 months) build a detailed model and blueprint for the Corridor's design and construction
- A second component is liaison with **Israeli security concerns** to ensure that view is directly inputted into the optioneering and modelling work so the final output mitigates this risk
- A third component is a review of all the **legal and planning documentation** that has been previously assembled, including the maps and agreements used in the various negotiations and the planning processes and protected land restrictions embedded in the Israeli planning system
- Alongside this work, which could start as early as June 2024, the broader Palestine Emerging partnership will be **working with international funders** and organisations on a potential to support the Corridor's build, as well as **laying the groundwork for hearts and minds** in Israel

GTUR | Third example: Technical University of Reconstruction

- Big university brands bring in billions of dollars of foreign direct investment, tapping into the global \$740bn tertiary education market and university development investment
- There is no major global institution that specialises in economic reconstruction and development, despite there being almost 300 armed conflicts since WW2, together with natural catastrophes with similar economic impacts
- 40 years of investment in human development have been wiped out, requiring a massive influx of human capital to manage reconstruction. It is better to train Palestinians rather than import development professionals
- This vocational emphasis will complement the research capabilities of a consortium of global universities and consultancies best sited in Gaza, or at first in the West Bank
- Led by a Palestinian university, GTUR will significantly add to the local ecosystem, giving it global reach and impact

GTUR | Short and Long-Term Development

- Tertiary educational needs in Gaza are massive. An entire cohort has lost a year, every university building has been destroyed, all faculties are displaced, and management dispersed
- This makes immediate needs paramount for most efforts, which involves in particular getting laptops to students and providing access to West Bank and international online courses, as well as funding students and providing specific support to them so studies can be restarted
- Palestine Emerging strongly supports these efforts and seeks to connect to and build on them
- The main work is to put in place feasible foundations and funding for a new global degree-granting institution specialising in post-conflict economic reconstruction and development
- Initially, the institution will need to be sited in Jerusalem or the West Bank, where it can begin to build its curriculum, brand and fundraising, working through the business development cycle
- Its initial scope will be vocational, training and upskilling Palestinians in the profession needed to deliver Gaza reconstruction, lessening the need for global development professionals
- As a significant component of Corporate Social Responsibility and ESG, specialist resource is sought from global universities and consultants to rapidly progress planning and delivery of the GTUR over the next months, so that its vocational component can contribute to reconstruction

GTUR | Vital Statistics

- **Economic necessity:** A central requirement for sustainable economic reconstruction and long-term growth for the West Bank and Gaza through a massive upskilling of the population, linked to vocational needs in real-time reconstruction projects
- **Global Demand:** No tertiary speciality institution of note exists in the world, creating a significant market opportunity Gaza can exploit to its advantage for fundraising
- **Cost:** Using proxy estimates, the estimated cost for this is around \$800m, with a short-term interim cost of some \$1m per year to design a curriculum and several MOOCs (~\$400k per course) and then run them, (\$50k per year)
- **Benefit:** based on available university multiplier models, the economic impact is some \$4.8 per \$1 in economic impact, and a central driver in reducing long-term unemployment
- **Local partner:** Several Palestinian universities have expressed an interest in being the local development partner for GTUR, contributing staff to the development team

GTUR | 12-Month Development Plan

Business development resource sought from global consortium of universities

Activity Start May 2024	2024								2025									
	5	6	7	8	9	10	11	12	1	2	3	4	5	6	7	8	9	10
Local engagement workshops	█																	
Business Model, Legal, Regulatory			█															
Interim Online Campus	█																	
Academic Partnerships Agreed			█															
Institutional Design Blueprint							█											
Materials produced				█														
Build and Establishment Costings								█										
Fundraising						█												
Survey and Locational Optioneering										█								

ECONOMIC RECONSTRUCTION AND GROWTH

20 MAY 2024

PREP

the work done so far

THE PLAN

what is it ?

GAMECHANGERS

where we are now

NEXT STEPS

what do we want from you

NEXT STEPS | How Can You Help ?

...economic expertise

specialist knowledge and resource is needed to support the economic backbone and model economic support in this area would be very much welcomed by the partnership

...other input and expertise

with the initial vision out, partnership is widening, as it adapts and develops input and help is sought from similar/relevant specialisms, pro bono support and drive

...spread the word

pushing out the wok as widely as possible

...especially to policymakers

with the strong case for a unitary economic plan that works with the wider agenda

...and links to other work

adding to the website repository of relevant long-term work on the Palestinian economy linking this work to other relevant plans and processes to interact and synthesise

Thank you

contact@palestine-emerging.org

